

143

No. IV-210/1/3/2010-Prov-I
Government of India
Ministry of Home Affairs

26, Man Singh Road, Jaisalmer House,
New Delhi, 23.2.2010

To
The DG: CRPF

Subject:- QRs/Technical Specifications for the Special Equipments for CoBRA Bns.

The QRs/ Technical Specifications in respect of the following Special Equipments for CoBRA Bns as per Appendix, has been accepted by the Competent Authority in MHA.

- ✓(1) Foldable Solar Charger-Appendix-A
- ✓(2) Compact light weight stainless steel multi utility tool- Appendix-B
- ✓(3) Light Weight ballistic protective eyewear against grenade blasts-Appendix-C
- ✓(4) Tactical 3 points sling universal- Appendix-D
- ✓(5) Waist belt nylon with buckle and rings for facilitating slithering/rappelling- Appendix-E
- ✓(6) Jungle Floppy Hat-Appendix-F
- ✓(7) Balaclava with convertible properties as Cap Comforter, Facemask and Cold Weather Muffler-Appendix-G
- ✓(8) Nylon Life Jacket with expandable Ployethylene Foam, Buckle and Whistle Plastic-Appendix-H

2. Henceforth, CRPF should procure the above equipments required by them strictly as per the laid down Technical Specifications/QRs.

1211
157 PWS

महानिदेशक अतिव सहायक संख्या.....
DG's Sectt. Diary No.	378/CM/110
महानिदेशक / Director General.....
अ. महानिदेशक / Add. D.G.
तिथि / Date	05 MAR 2010
प्रति. कार्य/परि/प्रशि/संभरण/प्रशा./निर्माण.....
वि.सं./निदेशक (विश्विस्ता).....
IG-Pers/Ops/Tig/Prov/Adm/Works.....
FA/Director (Medical).....

23/2/10
(R.S.Sharma)
Director (Prov)

4572
1/2 Prov.
V-Li
5/2
Copy to 195 AF

Dir (Prov)

2/3
De Prov

**CENTRAL RESERVE POLICE FORCE (CoBRA)
STANDARD**



**SPECIFICATION FOR “BALACLAVA WITH
CONVERTIBLE PROPERTIES AS CAP
COMFORTER, FACEMASK AND COLD WEATHER
MUFFLER”**

Submitted to :

**Office of the Inspector General of Police, CoBRA Sector
CRPF, Sector –IV, PUSHP VIHAR,
New Delhi-110017**

Prepared by :

**NORTHERN INDIA TEXTILE RESEARCH ASSOCIATION
Sector-23, Raj Nagar, Ghaziabad (U.P.)**

Email : mail@nitratextile.org

Fax: 0120-2783596



NORTHERN INDIA TEXTILE RESEARCH ASSOCIATION
Sector-23, Raj Nagar, Ghaziabad (U.P.)

Email: mail@nitratextile.org Fax: 0120-2783596

**SPECIFICATION FOR “BALACLAVA WITH
CONVERTIBLE PROPERTIES AS CAP COMFORTER,
FACEMASK AND COLD WEATHER MUFFLER”**

RECORD OF AMENDMENTS

Amendment No. and Date	Amendment pertains to Sl.No./Para No./Column No.	Authority	Amended by Name and Appointment (in block letter)	Signature and Date

PREAMBLE

The Inspector General of Police (CoBRA Sector), CRPF, has asked NITRA to prepare technical specifications for specification for “Balaclava with convertible properties as cap comforter, facemask and cold weather muffler”. The specification describes the performance requirements and material properties – course/dm, knit structure, weight, yarn count, fibre composition, dimensions, color fastness to light, washing, and perspiration; pH, dimensional change due to washing, etc. Bureau of Indian Standards (BIS) and American Association of Textile Chemists and Colorists (AATCC) test methods are considered to draw this specification.

This report contains 13 pages which describe the technical specifications of “Balaclava with convertible properties as cap comforter, facemask and cold weather muffler” for CRPF (CoBRA).

Whenever a reference to any other standard occurs in this specification, it shall be taken as reference to the latest version of that standard existing at the time of finalization of a contract.

This technical specification will enable the CRPF (CoBRA) to prepare tender documents (technical details) at the time of placing orders for “Balaclava with convertible properties as cap comforter, facemask and cold weather muffler” and final inspection as well.

**SPECIFICATION FOR “BALACLAVA WITH
CONVERTIBLE PROPERTIES AS CAP COMFORTER,
FACEMASK AND COLD WEATHER MUFFLER”**

C O N T E N T S

ITEM	SUBJECT	PAGE NO.
0	FORWARD	1
1	SCOPE	3
2	MATERIAL AND MANUFACTURE	3
3	STITCHING	4
4	WORKMANSHIP AND FINISH	4
5	SEALED SAMPLE	4
6	REQUIREMENTS	5
7	SAMPLING AND CRITERIA FOR CONFORMITY	9
8	MARKING	11
9	PACKAGING & PACKING	11
10	TERMINOLOGY	11
11	REFERANCES	12

0.0 FORWARD

0.0 This specification has been prepared by Office of the Inspector General of Police, CoBRA sector, CRPF on the authority of The Inspector General of Police, CoBRA sector.

0.1 This specification is for use by the CRPF - CoBRA.

0.2 This specification would be used for manufacture, quality assurance and procurement of the item.

0.3 Quality assurance authority for the item covered in this specification is Office of the Inspector General of Police, CoBRA Sector, CRPF, New Delhi. All enquiries regarding this specification, including those relating to any contractual conditions contained therein shall be addressed to the Quality Assurance authority at the following address:

Office of the Inspector General of Police, CoBRA Sector
CRPF, Sector –IV, PUSHP VIHAR,
New Delhi-110017

0.4 Copies of the specification can be obtained from:

Office of the Inspector General of Police, CoBRA Sector
CRPF, Sector –IV, PUSHP VIHAR,
New Delhi-110017

0.5 This specification holds good only for the supply order for which it is issued.

- 0.6 The Quality Assurance Authority reserves the right to amend or modify this specification as and when required.
- 0.7 The Quality Assurance Authority is the competent authority to grant concessions, if any, in respect of any clause contained in this specification
- 0.8 For the purpose of deciding whether a particular requirement of this specification is complied with, the final value, observed or calculated, expressing the result of a test, shall be rounded off in accordance with IS:2-1960 (Reaffirmed 2006). The number of significant places retained in the rounded off value should be the same as that of the specified value in this specification.

1.0 SCOPE

- 1.1 The specification prescribes the requirement of “Balaclava with convertible properties as cap comforter, facemask and cold weather muffler” herein referred as “Balaclava cap”.
- 1.2 This specification does not specify the general appearance, lusture, feel, type of finish of “Balaclava cap”

2.0 MATERIAL AND MANUFACTURE

- 2.1 The shape, dimensions and design of the “Balaclava cap” is shown in the Fig. 1.
- 2.2 The “Balaclava cap” shall be manufactured using 100% polyester filament yarn. For guidance, 80 denier polyester filament yarn may be used in the base of the knit structure, while 150 denier polyester multifilament filament yarns may be used in the fleece loop.
- 2.3 The “Balaclava cap” shall be made from knitted fabric using circular knitting machine. Polar fleece structure shall be used. The loops of the polar fleece shall be sheared (Form front side) while back side of the knitted fabric shall be raised before tailoring so as to ensure the required thickness. The finish of the “Balaclava cap” shall match with the sample held in the custody of CRPF-Cobra. The “Balaclava cap” shall be free from manufacturing defects such as broken thread in the body, large mends, ladders, dropped stitches, holes, cut, tears, etc. and any other defect, which may significantly affect the appearance or serviceability of “Balaclava cap” .

2.4 “Balaclava cap” shall be cut and tailored out of one pieces of seamless raised and sheared knitted tubular fabric.

3.0 STITCHING:

3.1 3-threads over lock stitch shall be employed to stitch the “face opening’ and to join the knitted fabric to make it tubular form. The stitch width shall be 4 mm and number of stitches shall be between 44 and 48 per dm. The bottom portion of the “Balaclava cap” shall be folded and lock stitched. The width of the fold shall be 25 mm and number of stitches shall be 44 to 48 per dm. The stitching shall be done with even tension and all loose ends shall be securely fastened off.

3.2 Sewing thread shall be of the green shade and conform IS: 9543: 1980 RA 2004). Spun polyester sewing thread 50s/3 Ne shall be used for this purpose.

4.0 WORKMANSHIP AND FINISH

The “Balaclava cap” shall be free from workmanship defects i.e. texture, knitting flaws etc. The “Balaclava cap” shall not have large mends, dropped stitches, ladders sewing defects, chemical damages and dyeing defects, such as uneven dyeing and streakiness.

5.0 SEALED SAMPLE

In order to illustrate or specify the indeterminable characteristics such as general appearance, luster, feel and design of the “Balaclava cap”, a sample has been agreed upon and sealed; the supply shall be conformity with the sample in such respects.

The custody of the sealed sample shall be a matter of prior agreement between the buyer and seller.

6.0 REQUIREMENTS

6.1 The “Balaclava cap” shall conform to the parameters as given in Table 2.

6.2 Specification for colour used in “Balaclava cap” shall be as given in Table 3.

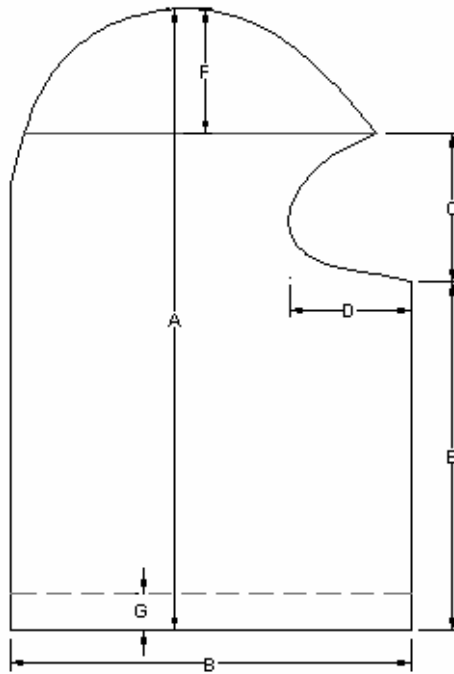

Fig.-1 Balaclava Cap

Table- 1 : Dimensions and mass of the “Balaclava cap”

Size	Dimensions (cm)							Minimum Mass of 10 caps (gram), (Test method A-3, IS:2783)
	A	B	C	D	E	F	G	
Small	38.0	23.0	9.6	7.6	20.0	8.0	2.5	500
Medium	40.0	25.0	9.8	7.8	22.0	8.2	2.5	600
Large	42.0	27.0	10.0	8.0	23.5	8.5	2.5	700
Tolerance	±1.0	±0.2	±0.2	±0.2	±0.2	±0.2	-	-

Table 2: Requirements of “Balaclava cap”

Sl. No.	Parameters	Requirements	Method of Testing
1.	Composition	100 % polyester	AATCC: 20-2007 & AATCC 20A-2008
2.	Courses /dm, Min	120	A-4, IS:2783-1976
3.	Thickness, mm, Minimum	2.0	IS: 7702 - 1975
4.	Dimensional Change (due to relaxation), percentage, Maximum -Lengthwise -Widthwise	2.0 2.0	A-5, IS:2783-1976
5.	Colour fastness to light	5 or better	IS: 2454-1985
6.	Colour fastness to washing - Change in colour - Staining on adjacent fabric	4 or better 4 or better	IS: 764 -1979
7.	Colour fastness to perspiration - Change in colour - Staining on adjacent fabric	4 or better 4 or better	IS: 971-1983
8.	pH Value of aqueous extract	6 to 8	IS :1390-1983 (Mild method)
9.	Colour difference (for all colours)(ΔE)	≤ 2.0	See Table 3

Table 3: Specification of colour of “Balaclava cap”

(AATCC Test method 173 : 2005 & AATCC Evaluation Procedure 7 : 2003)

Colour	:	Green		
System	:	CIE LCH		
Illuminant Observer	:	D 65		
Standard Observer	:	10 Degree		
Tristimulus Values	:	X	Y	Z
		4.492	4.724	3.393
L C H	:	L	C	H
		25.931	9.069	88.732
CMC (l:c)	:	2:1		
Colour difference, ΔE_{cmc}	:	≤ 2.0		

Interpretation of Results :

- i) If ΔE_{cmc} is less than or equal to 2, then sample is acceptable.
- ii) If ΔE_{cmc} is greater than 2, then sample is unacceptable.

Note-1 : Absorbance/reflectance/ transmittance are affected by surface characteristic features of the substrate. Therefore comparison should be made between samples of same type i.e., identical fabric construction parameters and filament/ fibre composition.

Note-2 : Test should be carried out after proper conditioning as per AATCC 173.

7.0 Sampling

7.1 The sampling procedure detailed in 7.2 and 7.3 shall give desired protection to the buyer and the seller, provided that the lot submitted for inspection is homogeneous. To achieve this, the manufacturer shall maintain a system of process control at all stages of manufacturing ensuring the “Balaclava cap” tendering by him for inspection to comply with the requirements of this standard in all respects.

7.2 The manufacturer should offer the stores serially numbered and arranged in such a way that the entire lot is accessible to the inspecting officer. The conforming of a lot to the requirement of this specification shall be determined on the basis of the tests carried out on the samples selected from it. The number of samples shall be selected at random in accordance with Table-4

Table-4: Number of “Balaclava cap” to be selected from a lot and permissible number of non-conforming “Balaclava cap”

No. of “Balaclava cap” in the lot (1)	Non – Destructive Testing		Destructive Testing	
	No. of “Balaclava cap” to be selected (2)	Permissible number of non-conforming “Balaclava cap” (3)	No. of “Balaclava cap” to be selected (4)	Permissible number of non-conforming “Balaclava cap” (5)
Up to 300	10	1	2	0
301 – 500	20	1	3	0
501-1000	30	2	5	0
1001 – 3000	50	3	8	0
3001 and above	80	5	13	1

Note: Sampling officer will select sampling unit randomly and select ultimate items from each sampling unit as per the above table.

7.3 **Lot:** For the purpose of conformance inspection and test sampling, a lot is defined as all the completed “Balaclava cap” of the same size and type, with same assemblies, produced in one facility, using the same production processes and materials, and being offered for delivery at one time to buyer against a dispatch note.

7.4 The CRPF (CoBRA) reserves the right to carry out inspection of bigger lot sizes, even to the extent of 100% inspection, if considered necessary.

7.5 The sample size and the criterion for conformity for various characteristics shall be as follows:

Characteristics	Sample size	Criteria for conformity
Freedom from defects, dimensions and number of courses/dm	All the “Balaclava cap” selected according to the column 2 of table 4	Non-conforming “Balaclava cap” not to exceed the corresponding number given in col. 3 of table 4
Mass, thickness	All the “Balaclava cap” selected according to the column 2 of table 4	Each observed value satisfies the specified requirement
Nature of fibre/filament, Dimensional change, pH value, colour fastness to various agencies other than colour fastness to light	All the “Balaclava cap” selected according to the column 4 of table 4	Non-conforming “Balaclava cap” not to exceed the corresponding number given in col. 5 of table 4
Colour fastness to light	One in case lot size is 500 “Balaclava cap” and two if lot size is 501 and above	Each “Balaclava cap” to satisfy the specified requirement.

8.0 MARKING

A cloth label marked with the following information shall be securely attached at the inside bottom portion of the 'balaclava Cap'. It should be adjacent to the place where the 'balaclava Cap' is stitched with 3-thread lock stitch.

- a) Size
- b) Name / Trademark of the manufacturer
- c) Any other information required by the buyer

9.0 PACKAGING & PACKING

9.1 Ten "Balaclava cap" suitably folded shall be wrapped with one layer of polyethylene film of minimum 40 microns (see IS: 2508-1963) and tied with twine at places to form a unit pack.

9.2 Twenty such unit packs (200 "Balaclava cap") shall be packed in polyethylene or polypropylene bags and or in box, as required by the buyer (see IS 2194 and IS 2195).

10. TERMINOLOGY

For the purpose of this standard the definitions as given in IS: 3596-1967 shall apply.

11.0 REFERENCES

Sl. No.	SPEC. /TEST METHOD No.	DESCRIPTION
(a)	AATCC 20 : 2007	Fibre analysis: Qualitative
(b)	AATCC 20A: 2008	Fibre analysis: Quantitative
(c)	IS 971: 1983, RA 2004	Method for determination of colour fastness of textile material to perspiration
(d)	IS 1390: 1983, RA 2004	Methods of testing of pH value of aqueous extract
(e)	IS 2454: 1985, RA 2006	Methods for determining of colour fastness of textile materials to artificial light (xenon lamp)
(f)	IS 2500 (Part 2): 1965, RA 2006	Sampling inspection tables
(g)	IS 764 : 1979, Reaffirmed 2008	Method for determination of colour fastness of textile material to washing
(h)	IS 4905: 1968, RA 2006	Method of random Sampling
(i)	IS 6359:1971, RA 2004	Method for Conditioning of Textiles
(j)	IS 783 : 1976, RA 2003	Specification for balaclava caps, wool, plain-knitted
(m)	AATCC Test method 173 : 2005	CMC: Calculation of small colour differences for acceptability
(n)	AATCC Evaluation Procedure 7 : 2003	Instrumental assessment of the change in colour of a test specimen