

भारतीय मानक

भोजन पकाने के स्टेनलेस इस्पात के बर्तनों की विशिष्टि

Indian Standard

**STAINLESS STEEL COOKING UTENSILS —
SPECIFICATION**

ICS 77.140.20; 97.040.60

© BIS 2000

BUREAU OF INDIAN STANDARDS
MANAK BHAVAN, 9 BAHADUR SHAH ZAFAR MARG
NEW DELHI 110002

FOREWORD

This Indian Standard was adopted by the Bureau of Indian Standards, after the draft finalized by the Utensils, Cutlery and Domestic Hardware Sectional Committee had been approved by the Mechanical Engineering Division Council.

Following Indian Standards covering requirements for various types of utensils have been published by this Sectional Committee:

- IS 3257 : 1980 Specification for stainless steel compartmental trays
- IS 3258 : 1980 Specification for stainless steel serving utensils
- IS 3411 : 1985 Specification for stainless steel cooking utensils
- IS 3424 : 1985 Specification for stainless steel table utensils

The Utensils, Cutlery and Domestic Hardware Sectional Committee while reviewing the above Indian Standards decided that all the above Indian Standards may be merged together so as to make the composite standard more user friendly and easy for reference purposes.

Requirements for sandwich bottom, composite bottom and copper electro-deposited/copper clad bottom stainless steel utensils are covered in various parts of IS 4536 (Part 1) : 1987 'Composite bottom stainless steel cooking utensils : Part 1 Copper electro-deposited (*first revision*)', IS 4536 (Part 2) : 1969 'Composite bottom stainless steel cooking utensils : Part 2 Ply construction', and IS 4536 (Part 3) : 1987 'Composite bottom stainless steel cooking utensils: Part 3 Copper clad'.

For the purpose of deciding whether a particular requirement of this standard is complied with, the final value, observed or calculated, expressing the result of a test or analysis, shall be rounded off in accordance with IS 2 : 1960 'Rules for rounding off numerical values (*revised*)'. The number of significant places retained in the rounded off value should be the same as that of specified value in the standard.

Indian Standard

STAINLESS STEEL COOKING UTENSILS — SPECIFICATION

1 SCOPE

This standard lays down the requirements for following types of stainless steel utensils:

- a) Cooking utensils,
- b) Serving utensils,
- c) Table utensils, and
- d) Storage utensils.

2 REFERENCES

The following Indian Standards are necessary adjuncts to this standard. At the time of publication, the editions indicated were valid. All standards are subject to revision, and parties to agreements based on this standard are encouraged to investigate the possibility of applying the most recent editions of the following standards:

IS No.	Title
5522 : 1992	Stainless steel sheets and strips for utensils (<i>second revision</i>)
9040 : 1978	Methods for sampling of utensils
13395 : 1995	Specification for performance of handles and handle assemblies

3 MATERIAL

The stainless steel used for manufacture of utensils shall conform to IS 5522.

4 GRADE

The stainless steel utensils shall have minimum thickness as specified. However, the utensils with higher thickness may be supplied, if required.

5 SHAPE AND DIMENSIONS

5.1 The shapes and dimensions for various types of utensils shall be as per the agreement between the purchaser and the supplier. However, some of the shapes of different types of utensils are given in Annex A for guidance.

5.2 The thickness of the sheet used and the minimum finished thickness of utensils shall conform to the requirements given in Table 1.

6 WORKMANSHIP AND FINISH

6.1 The utensils shall not have any sharp edges and shall be free from distortion, dents, wrinkles, scratches, pittings, deep tool marks and other surface defects. The utensils shall be bright finished and shall not rock when placed on flat surface.

**Table 1 Requirement for Thickness for
Sheet/Utensils
(Clause 5.2)**

Types of Utensils	Minimum Thickness for	
	Sheets (mm)	Utensils (mm)
Cooking utensils	0.9	0.7
Table utensils	0.7	0.55
Serving utensils	0.7	0.55
Storage utensils :		
Deep drawn	0.7	0.5
Fabricated	0.56	0.5

6.2 The construction of the utensils shall be such that it is possible to clean them thoroughly and all surfaces for cleaning are accessible by hand or brush.

6.3 Where handles are required, the requirements for handles shall conform to IS 13395.

7 TESTS

7.1 Staining Test

The utensils, when dipped for 16 h in each of the following solutions, shall not show any sign of staining after removal from the solutions at the end of above period:

- a) Ten grams of glacial acetic acid (99 percent) dissolved in distilled water to make 100 ml; and
- b) Five grams of pure sodium chloride dissolved in distilled water to make 100 ml.

8 SAMPLING

The sampling of utensils shall be done in accordance with IS 9040.

9 MARKING

Each utensil shall be legibly and indelibly marked by stamping 'Stainless Steel' or 'SS' and the manufacturer's name or initials or trade-mark and the category of the utensil.

9.1 BIS Certification Marking

9.1.1 The product may also be marked with BIS Standard Mark.

9.1.2 The use of the Standard Mark is governed by the provisions of the *Bureau of Indian Standards Act, 1986* and the 'Rules and Regulations made thereunder'. The details of conditions under which the license for use of Standard Mark may be granted to

manufacturers or producers may be obtained from the Bureau of Indian Standards.

10 PACKING

Utensils shall be wrapped in soft tissue paper and shall

be packed in accordance with the best trade practices or according to the instructions of the purchaser. Care shall be taken to see that the utensils do not get dented during transit.

ANNEX A

(Clause 5.1)

DIAGRAMMATIC SHAPE OF DIFFERENT TYPES OF UTENSILS

A-1 Diagrammatic shape of different types of utensils shall be as shown in Fig. 1 to 9. In these figures 'H' is the height and 'D' is the diameter.

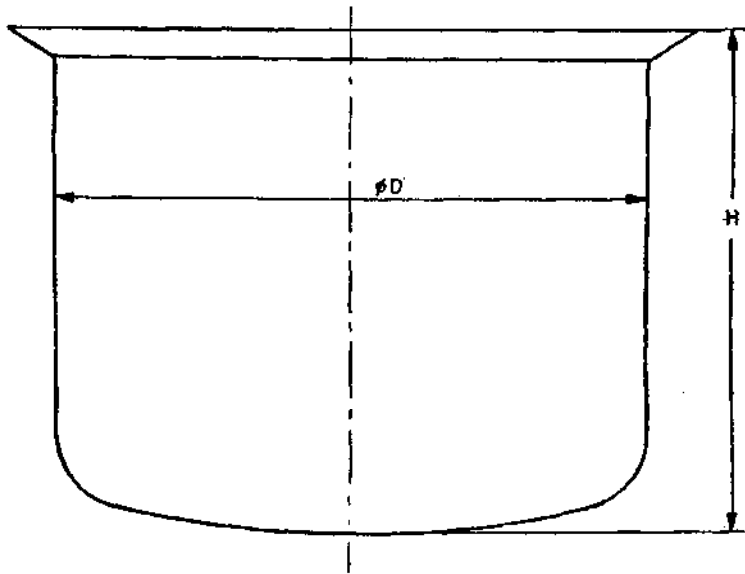

FIG. 1 DEEP DEGCHI

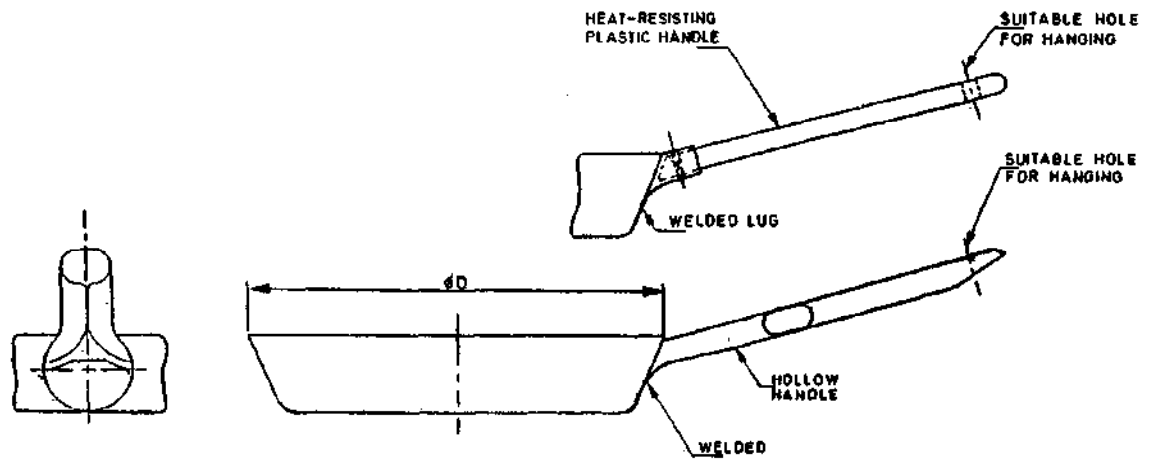

FIG. 2 FRYING PAN

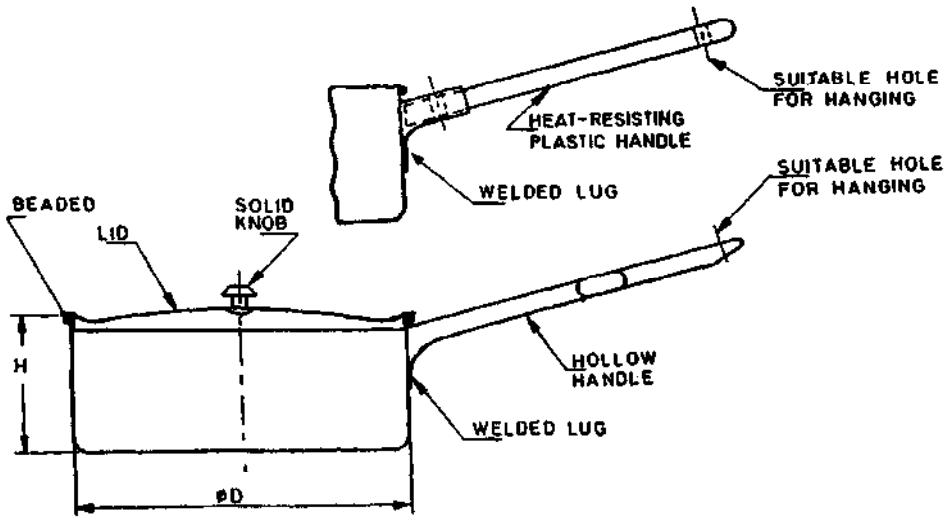

FIG. 3 SAUCEPAN

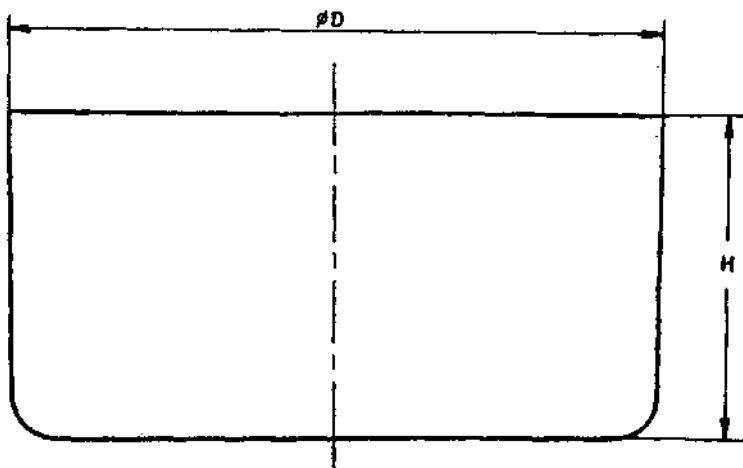

FIG. 4 KATORI

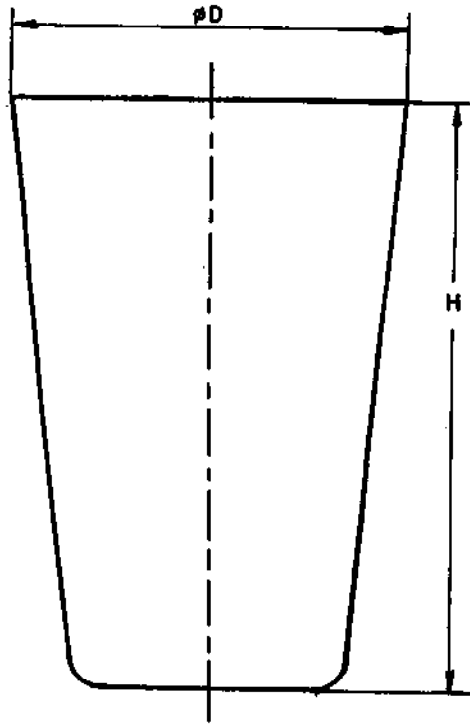

FIG. 5 TUMBLER

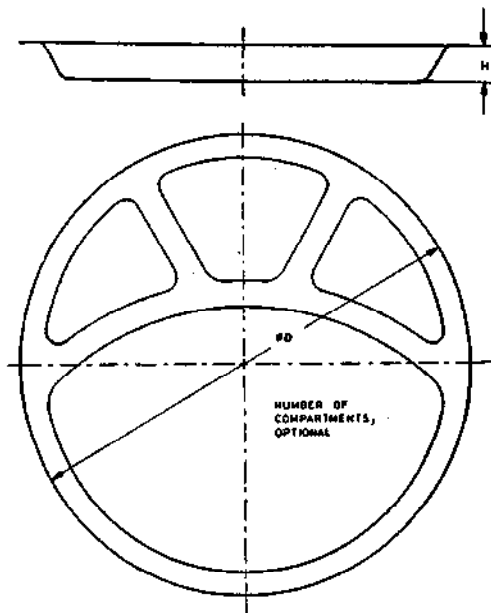

FIG. 6 COMPARTMENTAL TRAY ROUND

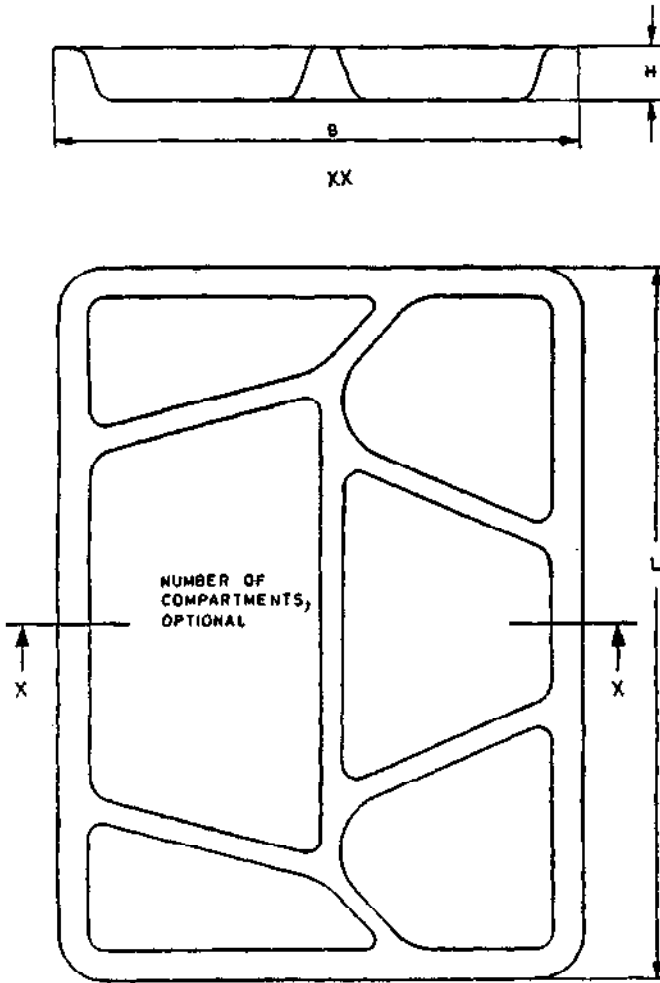

FIG. 7 COMPARTMENTAL TRAY, RECTANGULAR

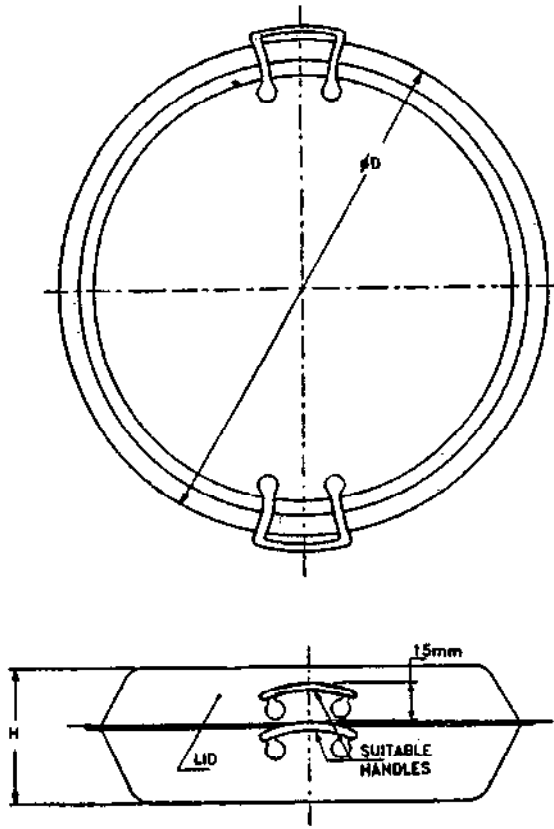

FIG. 8 ENTREE DISH, ROUND

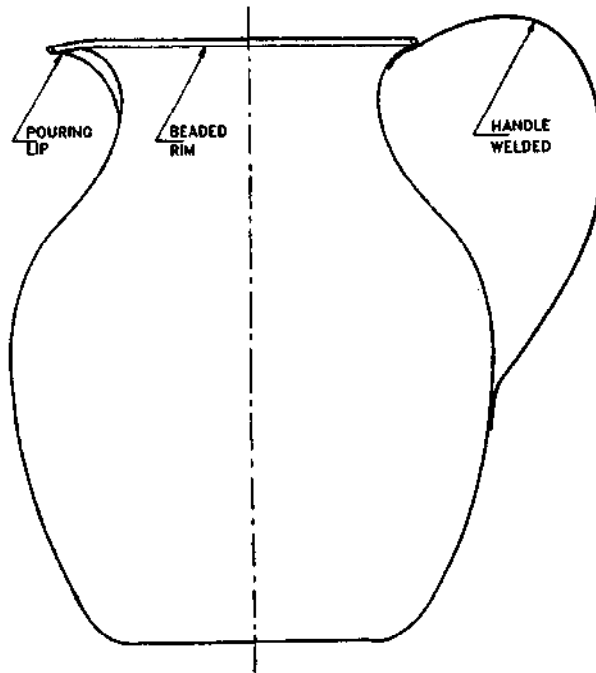

FIG. 9 JUG, TYPICAL

Bureau of Indian Standards

BIS is a statutory institution established under the *Bureau of Indian Standards Act, 1986* to promote harmonious development of the activities of standardization, marking and quality certification of goods and attending to connected matters in the country.

Copyright

BIS has the copyright of all its publications. No part of these publications may be reproduced in any form without the prior permission in writing of BIS. This does not preclude the free use, in the course of implementing the standard, of necessary details, such as symbols and sizes, type or grade designations. Enquiries relating to copyright be addressed to the Director (Publication), BIS

Review of Indian Standards

Amendments are issued to standards as the need arises on the basis of comments. Standards are also reviewed periodically; a standard along with amendments is reaffirmed when such review indicates that no changes are needed; if the review indicates that changes are needed, it is taken up for revision. Users of Indian Standards should ascertain that they are in possession of the latest amendments or edition by referring to the latest issue of 'BIS Handbook' and 'Standards: Monthly Additions'.

This Indian Standard has been developed from Doc: No. ME 33/LM 27 (4165)

Amendments Issued Since Publication

Amend No.	Date of Issue	Text Affected

BUREAU OF INDIAN STANDARDS

Headquarters:

Manak Bhavan, 9 Bahadur Shah Zafar Marg, New Delhi 110002
Telephones: 323 01 31, 323 3375, 323 94 02

Telegrams: Manaksanstha
(Common to all offices)

Regional Offices:

Central : Manak Bhavan, 9 Bahadur Shah Zafar Marg
NEW DELHI 110002

Telephone
323 76 17, 323 38 41

Eastern : 1/14 C.I.T. Scheme VII M, V.I.P. Road, Kankurgachi
CALCUTTA 700054

{ 337 84 99, 337 85 61
{ 337 86 26, 337 91 20

Northern : SCO 335-336, Sector 34-A, CHANDIGARH 160022

{ 60 38 43
{ 60 20 25

Southern : C.I.T. Campus, IV Cross Road, CHENNAI 600113

{ 235 02 16, 235 04 42
{ 235 15 19, 235 23 15

Western : Manakalaya, E9 MIDC, Marol, Andheri (East)
MUMBAI 400093

{ 832 92 95, 832 78 58
{ 832 78 91, 832 78 92

Branches : AHMADABAD. BANGALORE. BHOPAL. BHUBANESHWAR.
COIMBATORE. FARIDABAD. GHAZIABAD. GUWAHATI.
HYDERABAD. JAIPUR. KANPUR. LUCKNOW. NAGPUR.
PATNA. PUNE. RAJKOT. THIRUVANANTHAPURAM.